

# RING-WAVE-GENERATOR

## IPG 612c

**Oscillatory wave**

**Frequency 100 kHz**

**Rise time 0.5  $\mu$ s**

**Ring wave test  
according to IEEE 587**

**Ring wave test  
of RCCB's  
acc. to IEC 1008-1**



High-voltage pulse generator producing Ring Wave 0.5  $\mu$ s / 100 kHz acc. to IEEE 587.

The output peak voltage can be preset continuously from 0.2 - 6 kV. Rise time 0.5 $\mu$ s to the first peak, ringing frequency 100 kHz.

A built-in voltage divider allows monitoring of the output voltage waveform.

The generator comprises an electronically regulated high-voltage power supply, an energy storage capacitor, a high-voltage/high-current switch, a pulse forming network and a control- and monitoring unit.

Moreover, the generator includes a Coupling-/Decoupling Network (CDN) for single-phase power supply lines. External coupling-/decoupling networks for 3-phase power supply lines are controlled by a built-in optical interface.

The Ring Wave Generator IPG 612c features a microprocessor controlled user interface and display unit for ease of use. The microprocessor allows the user to execute either standard test routines, or a 'user defined' test sequence. The test parameters, which are shown on the built-in display, are easily adjusted by means of the rotary encoder. A standard parallel interface provides the ability to print a summary of the test parameters whilst testing is being carried out.

Moreover, all generator functions, including the settings of the built-in Coupling-/Decoupling Network, may be computer controlled via the isolated optical interface. The software program IPG-612c allows full remote control of the test generator and documentation and evaluation of test results.

The generator excels by its compact design, simple handling and precise reproducibility of test impulses.

**Technical specification:**
**IPG 612 c**

Microprocessor controlled LCD module	8*40 characters
Parallel printer interface for on-line documentation	25-way 'D' connector
Optical-interface for remote control of the generator	built-in
Diagnostic input for monitoring of the test device	4 channels, 5 V - Level
Impulse output voltage, adjustable	0.2 - 6.0 kV $\pm$ 10%
Output wave form acc. to IEEE 587	0.5 $\mu$ s /100 kHz
oscillation frequency	100 kHz $\pm$ 10%
rise time to the first peak	0.5 $\mu$ s $\pm$ 20%
Polarity of output voltage	+/-, selectable
Maximum stored energy	10 Ws
Charging time to maximum charging voltage	< 2 s
High-voltage outputs:	
HV 1: Series resistor	30 $\Omega$
max. short circuit output current	200 A
HV 2: Series resistor	12 $\Omega$
max. short circuit output current	500 A
COM: male connector, potential free	250 V/50 Hz, 1000 Vpeak
Impulse voltage divider integrated	ratio = 1000:1 $\pm$ 5%
Triggering: a) manual	Key
b) ext. trigger input	10V / 1k $\Omega$
c) internal, automatic	test procedure
Coupling-/decoupling network for power supply lines, built-in	L1, N, PE
rated voltage, rated current	250 V, 16 A $\approx$ / 10 A =
Connector for external safety interlock loop	24 V =
and external red and green warning lamps acc. to VDE 0104	230 V, 60W
Mains power	230 V, 50/60 Hz
Dimensions: desk top case      W * H * D	471*156*520 mm <sup>3</sup>
Weight	25 kg

Remote control of all generator functions via optically isolated computer interface

**OPTION 1** Software IPG-612c for remote control and documentation  
5 m fibre-optic cable and PC-interface

**OPTION 2:** Modification for testing residual current operated circuit breakers (RCCB)  
acc. to IEC 1008-1

**OPTION 3:** Safety test cover PA 503 for testing RCCB 's acc. to IEC 1008-1  
incl. Modification of IPG 612c

**Acc.:** Coupling-/decoupling networks for 3-phase interference test  
CDN 4416/4432/4464, CDN 2410

## Opt. 2: Ring Wave Test of RCCB's acc. to IEC 1008-1

The Ring-Wave Generator IPG 612c can be used for testing Residual Current operated Circuit Breakers (RCCB's) according to IEC 1008.

During this test each current path of the RCCB is loaded with a ring wave current. Up to peak current values of 250 A the RCCB may not be triggered.

OPTION 2 includes the modification of the generator and an additional current viewing resistor for monitoring the output current.

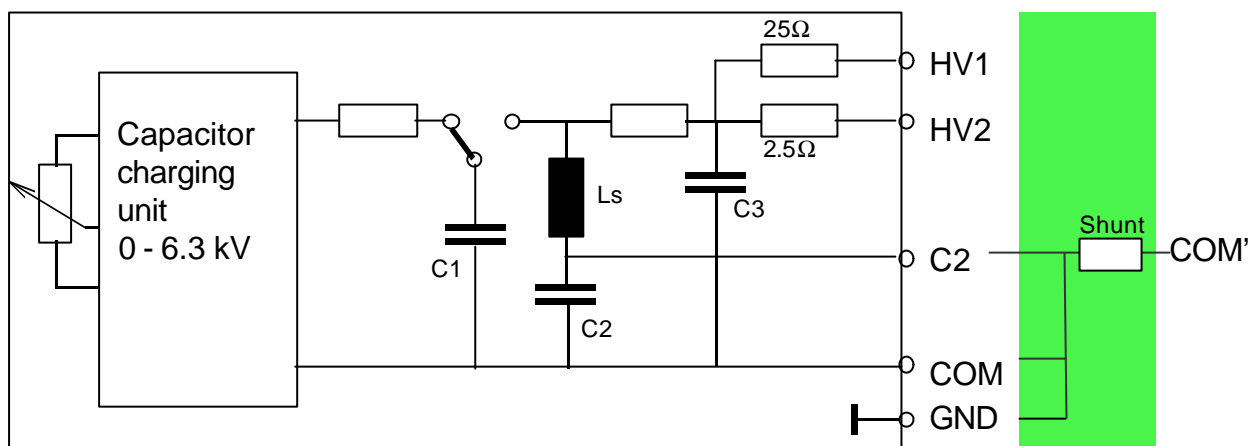

Fig. 1: Ring-Wave Generator IPG 612c, schematic

During EMC testing the ring wave generator is connected to the power supply terminals of the equipment under test. In order to avoid excessive mains currents through the pulse forming network there is a decoupling capacitor  $C_2$  connected in series to the resonant circuit inductor  $L_s = 5 \mu\text{H}$ , refer to IEEE 587. The 100 kHz short circuit output current is superimposed by an exponential decaying current with a time constant  $\tau \gg 10 \mu\text{s}$ .

This current is caused by discharging the capacitor  $C_2$ .

While testing Residual Current operated Circuit Breakers according to IEC 1008, this current may trigger the RCCB. In order to avoid this problem, the ring wave generator can be modified as follows:

1. The terminal of capacitor  $C_2$  is available on the rear panel.  $C_2$  can be shorted by inserting a connection bridge between  $C_2$  and COM.
2. In order to monitor the output current, a current viewing resistor  $R_m = 2 \text{ m}\Omega$  is connected in series to the COM-terminal and the additionally COM-terminal is connected to GND.

Modifications 1 and 2 are accomplished by connecting the specially designed SHUNT to the output terminals.

Protective earth terminals of the RCCB must be connected to the terminal COM'.

Additional accessories, see Option 3.

### Opt. 3: Ring Wave Test of RCCB's acc. to IEC 1008-1 including safety test cover PA 503:

The Ring-Wave Generator IPG 612c can be used for testing Residual Current operated Circuit Breakers (RCCB's) according to IEC 1008. During this test, each current path of the RCCB is loaded with a ring wave current. Up to peak current values of 250 A, the RCCB may not be triggered.

OPTION 2 includes the modification of the generator and an additional current viewing resistor for monitoring the output current.

In order to avoid human contact to the live parts of the output terminals and to provide for high level personal safety of the operator during impulse testing of RCCB's, the use of the safety test cover PA 503 is strongly recommended, see IEC 1008-1, Amend.1.

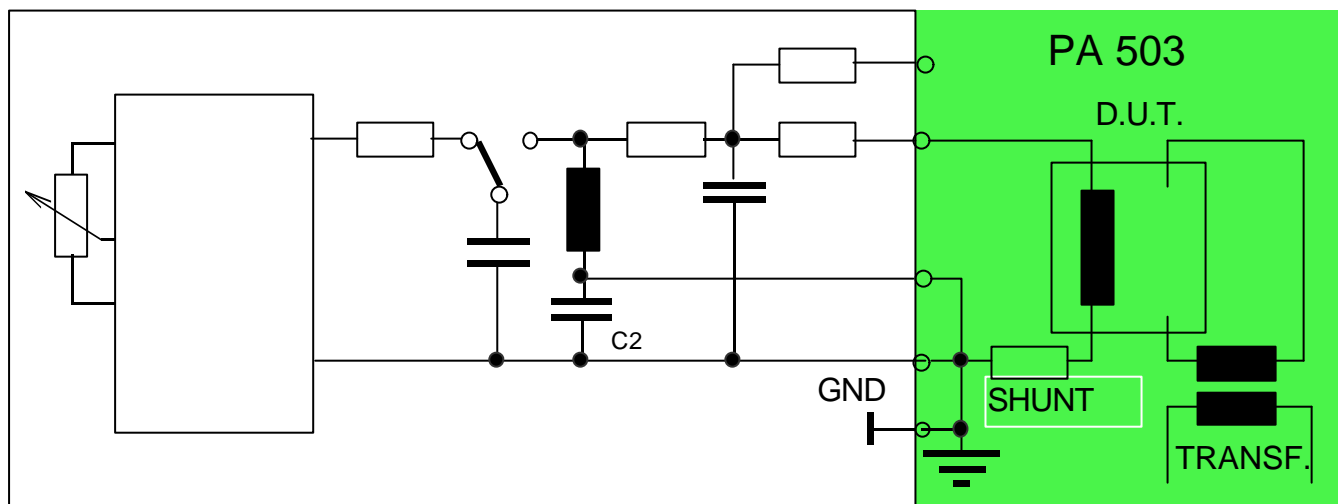

Fig. 2: Ring-Wave Generators IPG 612c, schematic, +Safety test cover PA 503, incl. modification of IPG 612c for testing RCCB's acc. to IEC 1008-1.

1. The terminal of capacitor  $C_2$  is available on the rear panel.  $C_2$  can be shorted by inserting a connection bridge between  $C_2$  and COM. The COM terminal is connected to GND.
2. In order to monitor the output current, a current viewing resistor  $R_m = 2 \text{ m}\Omega$  is connected between the test object and the COM/GND-terminal.
3. The high-voltage output HV1 or HV2 is connected to the safety test cover by use of a coaxial cable.
4. The safety test cover includes an isolating transformer with EMI-filter to supply the test object.
5. The limit switch of the safety test cover is connected to the safety interlock loop of the generator. Upon opening the safety test cover, the generator is shut down.